

系所組別：機械工程系碩士班丙組

科目：熱力與流力

(總分為 100 分；所有試題務必於答案卷內頁依序作答，否則不予計分)

1. Single choice questions (18%)

- I. (2%) Stream lines and path lines are always the same in case of
- uniform flow.
 - laminar flow.
 - steady flow.
 - turbulent flow.
- II. (2%) The total pressure force on a plane surface, which is inclined at an angle 9 degree with the horizontal, is equal to
- PA.
 - $PA \sin 9$.
 - $PA \cos 9$.
 - $PA \tan 9$.
- Here P is the pressure at the centroid of the plane surface area A.
- III. (2%) In the derivation of the Bernoulli equation, what is assumed to be negligible?
- pressure effects, (b) streamlines, (c) viscous effects, (d) gravity force.
- IV. (2%) For a body partially submerged in a fluid and at equilibrium, which of the following is a true statement?
- The weight of the body is equal to the weight of the volume of fluid displaced,
 - The weight of the body is less than the weight of the volume of fluid displaced,
 - The weight of the body is greater than the weight of the volume of fluid displaced,
 - The specific gravity of the body is greater than the specific gravity of the fluid.
- V. (2%) For the problem of vortex shedding frequency ω (1/s), the involved parameters include the depth D (m) and the height H (m) of the structure, the incident velocity V (m/s) of the fluid with the density ρ (kg/m^3) and the viscosity μ ($\text{N}\cdot\text{s/m}^2$). Please determine the number of dimensionless pi terms from these 6 physical parameters by using Buckingham Pi Theorem.
- 2, (b) 3, (c) 4, (d) 5.
- VI. (2%) Which of the following descriptions about "entropy" is TRUE?
- Entropy is an extensive property,
 - In an insulated system, the entropy during a process always increases or, in the limiting case of a reversible process, remains constant,
 - There are three ways to transfer entropy from or to a system: heat transfer, mass flow and work,
 - Entropy is a nonconserved property, which means that it is not conserved under any circumstances.
- VII. (2%) Which one of the following gases has constant-pressure specific heat c_p that does NOT depend on temperature?
- He, (b) O_2 , (c) H_2 , (d) H_2O , (e) CO_2 .



國立臺灣科技大學 111 學年度碩士班招生試題

系所組別：機械工程系碩士班丙組
 科目：熱力與流力

(總分為 100 分；所有試題務必於答案卷內頁依序作答，否則不予計分)

VIII.(2%) Which one of the following materials in solid phase will undergo sublimation under STP environment? (In the following statements, the subscript tp stands for triple point.)

- (a) Acetylene (C_2H_2 , $P_{tp} = 120 \text{ kPa}$, $T_{tp} = 192.4 \text{ K}$),
- (b) Ammonia (NH_3 , $P_{tp} = 6.076 \text{ kPa}$, $T_{tp} = 195.4 \text{ K}$),
- (c) Argon (Ar, $P_{tp} = 68.9 \text{ kPa}$, $T_{tp} = 83.81 \text{ K}$),
- (d) Hydrogen (H_2 , $P_{tp} = 7.04 \text{ kPa}$, $T_{tp} = 13.84 \text{ K}$),
- (e) Carbon monoxide (CO , $P_{tp} = 15.37 \text{ kPa}$, $T_{tp} = 68.1 \text{ K}$).

IX. (2%) Two Carnot heat engine that have the same thermal efficiency are operating in series such that the heat sink of the 1st engine serves as the heat source of the 2nd one. If the source temperature of the 1st engine is 1300K and the sink temperature of the 2nd engine is 300K, the temperature of the intermediate reservoir is

- (a) 625K, (b) 800K, (c) 1300K, (d) 300K.

2. Multiple choice questions (12%) 各小題各 3 分，需全部選項均答對才給分

I. (3%) Which one of the following is a steady flow device?

- (a) A pump,
- (b) A throttle valve,
- (c) A rocket engine,
- (d) A nozzle,
- (e) A heat exchanger.

II. (3%) Which of the following processes are made up for an ideal Carnot cycle?

- (a) Reversible constant temperature expansion,
- (b) Reversible adiabatic expansion,
- (c) Reversible isothermal compression,
- (d) Isentropic compression,
- (e) Isobaric heat addition.

III. (3%) Which of the following statements are TRUE for an ideal gas?

- (a) Internal energy depends only on the temperature and pressure,
- (b) Enthalpy depends only on the temperature,
- (c) No intermolecular force existing between gas molecules,
- (d) Temperature remains constant during a throttling process,
- (e) Entropy varies with specific volume or pressure as well as temperature.

IV. (3%) Which of the following statements are equivalent?

- (a) It is impossible to construct a device that operates in a cycle and produces no effect other than the transfer of heat from a lower-temperature body to a higher-temperature body.
- (b) The thermal efficiencies of all reversible heat engines are the same, and no heat engine is more efficient than a reversible one.
- (c) It is impossible for any device that operates on a cycle to receive heat from a single reservoir and produce a net amount of work.
- (d) The entropy of an isolated system during a process always increases.



國立臺灣科技大學 111 學年度碩士班招生試題

系所組別：機械工程系碩士班丙組

科目：熱力與流力

(總分為 100 分；所有試題務必於答案卷內頁依序作答，否則不予計分)

3. (10%) A jet of oil ($SG = 0.8$) strikes a curved blade that turns the fluid through the angle $\theta = 180^\circ$. The jet area is 1200 mm^2 and its speed relative to the stationary nozzle is 20 m/s . The blade moves toward the nozzle at 10 m/s . Determine the force that must be applied to maintain the blade speed constant. (Hint: Use the relative velocity to in your momentum equation.)

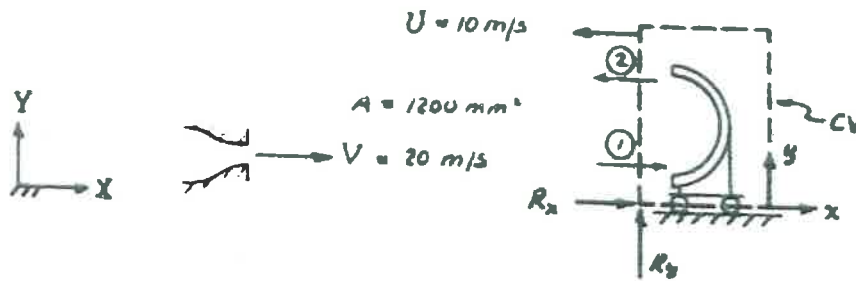

4. (15%) Water flows from a very large tank through a tube of 8-cm diameter. The dark liquid in the manometer is mercury. Estimate the velocity in the pipe and the rate of discharge from the tank. (Assume the flow is frictionless.) $SG_{\text{Hg}} = 13.6$.

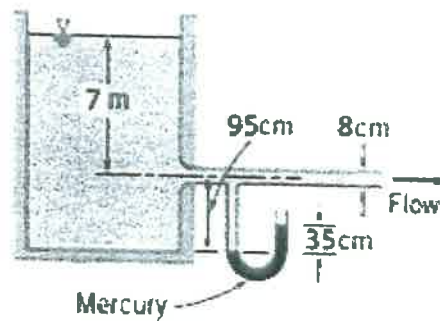

5. (15%) For a two-dimensional flow field, the x and the y velocity components are given by $u = 3x^2 - 3y^2$ and $v = -6xy$ (unit: m/sec), respectively
- (3%) Is it an incompressible or compressible flow?
 - (3%) Is it a steady or unsteady flow?
 - (3%) Find the stream function for this flow field if it is possible.
 - (3%) Find the stream-line(s) passing through the origin.
 - (3%) What is the volumetric flow rate of fluid crossing the surface **OB**?

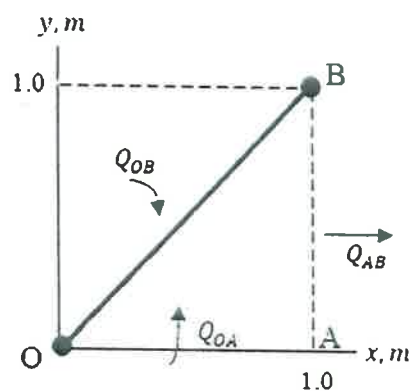

國立臺灣科技大學 111 學年度碩士班招生試題

系所組別：機械工程系碩士班丙組

科目：熱力與流力

(總分為 100 分；所有試題務必於答案卷內頁依序作答，否則不予計分)

6. (10%) An insulated rigid tank is separated into two 1 m^3 chambers by a frictionless piston locked by a pin. The left chamber is filled with air (gas constant $R = 0.287 \text{ kJ/kg} \cdot \text{K}$) at a pressure of 250 kPa, and the right chamber is filled with air at a pressure of 150 kPa. The two chambers are maintained in thermal equilibrium with each other and the piston inside is not adiabatic. If the pin is now removed and the frictionless piston is allowed to move freely, the system will reach a new equilibrium state again. Please answer the following questions:
- (3%) Determine the final equilibrium pressure and temperature change during the process.
 - (3%) Determine the final volumes of each chamber.
 - (4%) If the right chamber is filled with helium (gas constant $R = 2.077 \text{ kJ/kg} \cdot \text{K}$) instead of air, determine the final volumes of each chamber.
7. (10%) A throttle valve is placed in steam line to control the power output of a steam turbine. Steam at 7 MPa and 400°C is supplied at the throttle inlet, and the turbine exhaust pressure is at 70 kPa. Assuming negligible pressure drop in the pipelines, please answer the following questions:
- (5%) Determine the work output of the steam turbine when the throttle valve is completely open and the turbine is considered isentropic.
 - (5%) Determine the increase of the entropy per unit mass of the steam in the process when the throttle valve is partially closed so that the pressure at the turbine inlet is 4 MPa and the turbine's isentropic efficiency drops to 95%.

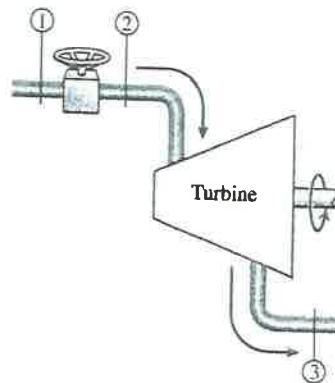

8. (10%) 0.05 m^3 of air is contained in the spring-loaded piston cylinder device. The spring constant is 850 N/m , and the piston diameter is 25 cm . When no force is exerted by the spring on the piston, the state of the air is 2300 kPa and 250°C . This device is now cooled until the volume is one-half of its original size. Please determine the change in the specific internal energy and the enthalpy of the air.

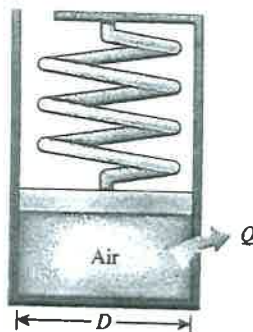

國立臺灣科技大學 111 學年度碩士班招生試題

系所組別：機械工程系碩士班丙組

科目：熱力與流力

(總分為 100 分；所有試題務必於答案卷內頁依序作答，否則不予計分)

Ideal-gas properties of air

T K	h kJ/kg	P_r	u kJ/kg	v_r	s° kJ/kg·K	T K	h kJ/kg	P_r	u kJ/kg	v_r	s° kJ/kg·K
200	199.97	0.3363	142.56	1707.0	1.29559	580	586.04	14.38	419.55	115.7	2.37348
210	209.97	0.3987	149.69	1512.0	1.34444	590	596.52	15.31	427.15	110.6	2.39140
220	219.97	0.4690	156.82	1346.0	1.39105	600	607.02	16.28	434.78	105.8	2.40902
230	230.02	0.5477	164.00	1205.0	1.43557	610	617.53	17.30	442.42	101.2	2.42644
240	240.02	0.6355	171.13	1084.0	1.47824	620	628.07	18.36	450.09	96.92	2.44356
250	250.05	0.7329	178.28	979.0	1.51917	630	638.63	19.84	457.78	92.84	2.46048
260	260.09	0.8405	185.45	887.8	1.55848	640	649.22	20.64	465.50	88.99	2.47716
270	270.11	0.9590	192.60	808.0	1.59634	650	659.84	21.86	473.25	85.34	2.49364
280	280.13	1.0889	199.75	738.0	1.63279	660	670.47	23.13	481.01	81.89	2.50985
285	285.14	1.1584	203.33	706.1	1.65055	670	681.14	24.46	488.81	78.61	2.52589
290	290.16	1.2311	206.91	676.1	1.66802	680	691.82	25.85	496.62	75.50	2.54175
295	295.17	1.3068	210.49	647.9	1.68515	690	702.52	27.29	504.45	72.56	2.55731
298	298.18	1.3543	212.64	631.9	1.69528	700	713.27	28.80	512.33	69.76	2.57277
300	300.19	1.3860	214.07	621.2	1.70203	710	724.04	30.38	520.23	67.07	2.58810
305	305.22	1.4686	217.67	596.0	1.71865	720	734.82	32.02	528.14	64.53	2.60319
310	310.24	1.5546	221.25	572.3	1.73498	730	745.62	33.72	536.07	62.13	2.61803
315	315.27	1.6442	224.85	549.8	1.75106	740	756.44	35.50	544.02	59.82	2.63280
320	320.29	1.7375	228.42	528.6	1.76690	750	767.29	37.35	551.99	57.63	2.64737
325	325.31	1.8345	232.02	508.4	1.78249	760	778.18	39.27	560.01	55.54	2.66176
330	330.34	1.9352	235.61	489.4	1.79783	780	800.03	43.35	576.12	51.64	2.69013
340	340.42	2.149	242.82	454.1	1.82790	800	821.95	47.75	592.30	48.08	2.71787
350	350.49	2.379	250.02	422.2	1.85708	820	843.98	52.59	608.59	44.84	2.74504
360	360.58	2.626	257.24	393.4	1.88543	840	866.08	57.60	624.95	41.85	2.77170
370	370.67	2.892	264.46	367.2	1.91313	860	888.27	63.09	641.40	39.12	2.79783
380	380.77	3.176	271.69	343.4	1.94001	880	910.56	68.98	657.95	36.61	2.82344
390	390.88	3.481	278.93	321.5	1.96633	900	932.93	75.29	674.58	34.31	2.84856
400	400.98	3.806	286.16	301.6	1.99194	920	955.38	82.05	691.28	32.18	2.87324
410	411.12	4.153	293.43	283.3	2.01699	940	977.92	89.28	708.08	30.22	2.89748
420	421.26	4.522	300.69	266.6	2.04142	960	1000.55	97.00	725.02	28.40	2.92128
430	431.43	4.915	307.99	251.1	2.06533	980	1023.25	105.2	741.98	26.73	2.94468
440	441.61	5.332	315.30	236.8	2.08870	1000	1046.04	114.0	758.94	25.17	2.96770
450	451.80	5.775	322.62	223.6	2.11161	1020	1068.89	123.4	776.10	23.72	2.99034
460	462.02	6.245	329.97	211.4	2.13407	1040	1091.85	133.3	793.36	23.29	3.01260
470	472.24	6.742	337.32	200.1	2.15604	1060	1114.86	143.9	810.62	21.14	3.03449
480	482.49	7.268	344.70	189.5	2.17760	1080	1137.89	155.2	827.88	19.98	3.05608
490	492.74	7.824	352.08	179.7	2.19876	1100	1161.07	167.1	845.33	18.896	3.07732
500	503.02	8.411	359.49	170.6	2.21952	1120	1184.28	179.7	862.79	17.886	3.09825
510	513.32	9.031	366.92	162.1	2.23993	1140	1207.57	193.1	880.35	16.946	3.11883
520	523.63	9.684	374.36	154.1	2.25997	1160	1230.92	207.2	897.91	16.064	3.13916
530	533.98	10.37	381.84	146.7	2.27967	1180	1254.34	222.2	915.57	15.241	3.15916
540	544.35	11.10	389.34	139.7	2.29906	1200	1277.79	238.0	933.33	14.470	3.17888
550	555.74	11.86	396.86	133.1	2.31809	1220	1301.31	254.7	951.09	13.747	3.19834
560	565.17	12.66	404.42	127.0	2.33685	1240	1324.93	272.3	968.95	13.069	3.21751
570	575.59	13.50	411.97	121.2	2.35531						

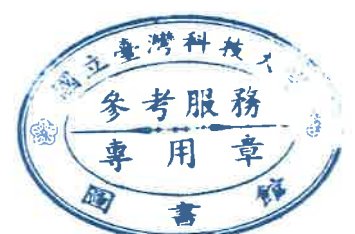

國立臺灣科技大學 111 學年度碩士班招生試題

系所組別：機械工程系碩士班丙組

科目：熱力與流力

(總分為 100 分；所有試題務必於答案卷內頁依序作答，否則不予計分)

Saturated water—Pressure table

Press., P kPa	Sat. temp., T_{sat} °C	Specific volume, m^3/kg		Internal energy, kJ/kg			Enthalpy, kJ/kg			Entropy, kJ/kg·K		
		Sat. liquid, v_f	Sat. vapor, v_g	Sat. liquid, u_f	Evap., u_{fg}	Sat. vapor, u_g	Sat. liquid, h_f	Evap., h_{fg}	Sat. vapor, h_g	Sat. liquid, s_f	Evap., s_{fg}	Sat. vapor, s_g
1.0	6.97	0.001000	129.19	29.302	2355.2	2384.5	29.303	2484.4	2513.7	0.1059	8.8690	8.9749
1.5	13.02	0.001001	87.964	54.686	2338.1	2392.8	54.688	2470.1	2524.7	0.1956	8.6314	8.8270
2.0	17.50	0.001001	66.990	73.431	2325.5	2398.9	73.433	2459.5	2532.9	0.2606	8.4621	8.7227
2.5	21.08	0.001002	54.242	88.422	2315.4	2403.8	88.424	2451.0	2539.4	0.3118	8.3302	8.6421
3.0	24.08	0.001003	45.654	100.98	2306.9	2407.9	100.98	2443.9	2544.8	0.3543	8.2222	8.5765
4.0	28.96	0.001004	34.791	121.39	2293.1	2414.5	121.39	2432.3	2553.7	0.4224	8.0510	8.4734
5.0	32.87	0.001005	28.185	137.75	2282.1	2419.8	137.75	2423.0	2560.7	0.4762	7.9176	8.3938
7.5	40.29	0.001008	19.233	168.74	2261.1	2429.8	168.75	2405.3	2574.0	0.5763	7.6738	8.2501
10	45.81	0.001010	14.670	191.79	2245.4	2437.2	191.81	2392.1	2583.9	0.6492	7.4996	8.1488
15	53.97	0.001014	10.020	225.93	2222.1	2448.0	225.94	2372.3	2598.3	0.7549	7.2522	8.0071
20	60.06	0.001017	7.6481	251.40	2204.6	2456.0	251.42	2357.5	2608.9	0.8320	7.0752	7.9073
25	64.96	0.001020	6.2034	271.93	2190.4	2462.4	271.96	2345.5	2617.5	0.8932	6.9370	7.8302
30	69.09	0.001022	5.2287	289.24	2178.5	2467.7	289.27	2335.3	2624.6	0.9441	6.8234	7.7675
40	75.86	0.001026	3.9933	317.58	2158.8	2476.3	317.62	2318.4	2636.1	1.0261	6.6430	7.6691
50	81.32	0.001030	3.2403	340.49	2142.7	2483.2	340.54	2304.7	2645.2	1.0912	6.5019	7.5931
75	91.76	0.001037	2.2172	384.36	2111.8	2496.1	384.44	2278.0	2662.4	1.2132	6.2426	7.4558
100	99.61	0.001043	1.6941	417.40	2088.2	2505.6	417.51	2257.5	2675.0	1.3028	6.0562	7.3589
101.325	99.97	0.001043	1.6734	418.95	2087.0	2506.0	419.06	2256.5	2675.6	1.3069	6.0476	7.3545
125	105.97	0.001048	1.3750	444.23	2068.8	2513.0	444.36	2240.6	2684.9	1.3741	5.9100	7.2841
150	111.35	0.001053	1.1594	466.97	2052.3	2519.2	467.13	2226.0	2693.1	1.4337	5.7894	7.2231
175	116.04	0.001057	1.0037	486.82	2037.7	2524.5	487.01	2213.1	2700.2	1.4850	5.6865	7.1716
200	120.21	0.001061	0.88578	504.50	2024.6	2529.1	504.71	2201.6	2706.3	1.5302	5.5968	7.1270
225	123.97	0.001064	0.79329	520.47	2012.7	2533.2	520.71	2191.0	2711.7	1.5706	5.5171	7.0877
250	127.41	0.001067	0.71873	535.08	2001.8	2536.8	535.35	2181.2	2716.5	1.6072	5.4453	7.0525
275	130.58	0.001070	0.65732	548.57	1991.6	2540.1	548.86	2172.0	2720.9	1.6408	5.3800	7.0207
300	133.52	0.001073	0.60582	561.11	1982.1	2543.2	561.43	2163.5	2724.9	1.6717	5.3200	6.9917
325	136.27	0.001076	0.56199	572.84	1973.1	2545.9	573.19	2155.4	2728.6	1.7005	5.2645	6.9650
350	138.86	0.001079	0.52422	583.89	1964.6	2548.5	584.26	2147.7	2732.0	1.7274	5.2128	6.9402
375	141.30	0.001081	0.49133	594.32	1956.6	2550.9	594.73	2140.4	2735.1	1.7526	5.1645	6.9171
400	143.61	0.001084	0.46242	604.22	1948.9	2553.1	604.66	2133.4	2738.1	1.7765	5.1191	6.8955
450	147.90	0.001088	0.41392	622.65	1934.5	2557.1	623.14	2120.3	2743.4	1.8205	5.0356	6.8561
500	151.83	0.001093	0.37483	639.54	1921.2	2560.7	640.09	2108.0	2748.1	1.8604	4.9603	6.8207
550	155.46	0.001097	0.34261	655.16	1908.8	2563.9	655.77	2096.6	2752.4	1.8970	4.8916	6.7886
600	158.83	0.001101	0.31560	669.72	1897.1	2566.8	670.38	2085.8	2756.2	1.9308	4.8285	6.7593
650	161.98	0.001104	0.29260	683.37	1886.1	2569.4	684.08	2075.5	2759.6	1.9623	4.7699	6.7322
700	164.95	0.001108	0.27278	696.23	1875.6	2571.8	697.00	2065.8	2762.8	1.9918	4.7153	6.7071
750	167.75	0.001111	0.25552	708.40	1865.6	2574.0	709.24	2056.4	2765.7	2.0195	4.6642	6.6837



國立臺灣科技大學 111 學年度碩士班招生試題

系所組別：機械工程系碩士班丙組
科目：熱力與流力

(總分為 100 分；所有試題務必於答案卷內頁依序作答，否則不予計分)

Superheated water (Continued)

T °C	v m ³ /kg	u kJ/kg	h kJ/kg	s kJ/kg·K	v m ³ /kg	u kJ/kg	h kJ/kg	s kJ/kg·K	v m ³ /kg	u kJ/kg	h kJ/kg	s kJ/kg·K
P = 4.0 MPa (250.35°C)				P = 4.5 MPa (257.44°C)				P = 5.0 MPa (263.94°C)				
Sat.	0.04978	2601.7	2800.8	6.0696	0.04406	2599.7	2798.0	6.0198	0.03945	2597.0	2794.2	5.9737
275	0.05461	2668.9	2887.3	6.2312	0.04733	2651.4	2864.4	6.1429	0.04144	2632.3	2839.5	6.0571
300	0.05887	2726.2	2961.7	6.3639	0.05138	2713.0	2944.2	6.2854	0.04535	2699.0	2925.7	6.2111
350	0.06647	2827.4	3093.3	6.5843	0.05842	2818.6	3081.5	6.5153	0.05197	2809.5	3069.3	6.4516
400	0.07343	2920.8	3214.5	6.7714	0.06477	2914.2	3205.7	6.7071	0.05784	2907.5	3196.7	6.6483
450	0.08004	3011.0	3331.2	6.9386	0.07076	3005.8	3324.2	6.8770	0.06332	3000.6	3317.2	6.8210
500	0.08644	3100.3	3446.0	7.0922	0.07652	3096.0	3440.4	7.0323	0.06858	3091.8	3434.7	6.9781
600	0.09886	3279.4	3674.9	7.3706	0.08766	3276.4	3670.9	7.3127	0.07870	3273.3	3666.9	7.2605
700	0.11098	3462.4	3906.3	7.6214	0.09850	3460.0	3903.3	7.5647	0.08852	3457.7	3900.3	7.5136
800	0.12292	3650.6	4142.3	7.8523	0.10916	3648.8	4140.0	7.7962	0.09816	3646.9	4137.7	7.7458
900	0.13476	3844.8	4383.9	8.0675	0.11972	3843.3	4382.1	8.0118	0.10769	3841.8	4380.2	7.9619
1000	0.14653	4045.1	4631.2	8.2698	0.13020	4043.9	4629.8	8.2144	0.11715	4042.6	4628.3	8.1648
1100	0.15824	4251.4	4884.4	8.4612	0.14064	4250.4	4883.2	8.4060	0.12655	4249.3	4882.1	8.3566
1200	0.16992	4463.5	5143.2	8.6430	0.15103	4462.6	5142.2	8.5880	0.13592	4461.6	5141.3	8.5388
1300	0.18157	4680.9	5407.2	8.8164	0.16140	4680.1	5406.5	8.7616	0.14527	4679.3	5405.7	8.7124
P = 6.0 MPa (275.59°C)				P = 7.0 MPa (285.83°C)				P = 8.0 MPa (295.01°C)				
Sat.	0.03245	2589.9	2784.6	5.8902	0.027378	2581.0	2772.6	5.8148	0.023525	2570.5	2758.7	5.7450
300	0.03619	2668.4	2885.6	6.0703	0.029492	2633.5	2839.9	5.9337	0.024279	2592.3	2786.5	5.7937
350	0.04225	2790.4	3043.9	6.3357	0.035262	2770.1	3016.9	6.2305	0.029975	2748.3	2988.1	6.1321
400	0.04742	2893.7	3178.3	6.5432	0.039958	2879.5	3159.2	6.4502	0.034344	2864.6	3139.4	6.3658
450	0.05217	2989.9	3302.9	6.7219	0.044187	2979.0	3288.3	6.6353	0.038194	2967.8	3273.3	6.5579
500	0.05667	3083.1	3423.1	6.8826	0.048157	3074.3	3411.4	6.8000	0.041767	3065.4	3399.5	6.7266
550	0.06102	3175.2	3541.3	7.0308	0.051966	3167.9	3531.6	6.9507	0.045172	3160.5	3521.8	6.8800
600	0.06527	3267.2	3658.8	7.1693	0.055665	3261.0	3650.6	7.0910	0.048463	3254.7	3642.4	7.0221
700	0.07355	3453.0	3894.3	7.4247	0.062850	3448.3	3888.3	7.3487	0.054829	3443.6	3882.2	7.2822
800	0.08165	3643.2	4133.1	7.6582	0.069856	3639.5	4128.5	7.5836	0.061011	3635.7	4123.8	7.5185
900	0.08964	3838.8	4376.6	7.8751	0.076750	3835.7	4373.0	7.8014	0.067082	3832.7	4369.3	7.7372
1000	0.09756	4040.1	4625.4	8.0786	0.083571	4037.5	4622.5	8.0055	0.073079	4035.0	4619.6	7.9419
1100	0.10543	4247.1	4879.7	8.2709	0.090341	4245.0	4877.4	8.1982	0.079025	4242.8	4875.0	8.1350
1200	0.11326	4459.8	5139.4	8.4534	0.097075	4457.9	5137.4	8.3810	0.084934	4456.1	5135.5	8.3181
1300	0.12107	4677.7	5404.1	8.6273	0.103781	4676.1	5402.6	8.5551	0.090817	4674.5	5401.0	8.4925
P = 9.0 MPa (303.35°C)				P = 10.0 MPa (311.00°C)				P = 12.5 MPa (327.81°C)				
Sat.	0.020489	2558.5	2742.9	5.6791	0.018028	2545.2	2725.5	5.6159	0.013496	2505.6	2674.3	5.4638
325	0.023284	2647.6	2857.1	5.8738	0.019877	2611.6	2810.3	5.7596				
350	0.025816	2725.0	2957.3	6.0380	0.022440	2699.6	2924.0	5.9460	0.016138	2624.9	2826.6	5.7130
400	0.029960	2849.2	3118.8	6.2876	0.026436	2833.1	3097.5	6.2141	0.020030	2789.6	3040.0	6.0433
450	0.033524	2956.3	3258.0	6.4872	0.029782	2944.5	3242.4	6.4219	0.023019	2913.7	3201.5	6.2749
500	0.036793	3056.3	3387.4	6.6603	0.032811	3047.0	3375.1	6.5995	0.025630	3023.2	3343.6	6.4651
550	0.039885	3153.0	3512.0	6.8164	0.035655	3145.4	3502.0	6.7585	0.028033	3126.1	3476.5	6.6317
600	0.042861	3248.4	3634.1	6.9605	0.038378	3242.0	3625.8	6.9045	0.030306	3225.8	3604.6	6.7828
650	0.045755	3343.4	3755.2	7.0954	0.041018	3338.0	3748.1	7.0408	0.032491	3324.1	3730.2	6.9227
700	0.048589	3438.8	3876.1	7.2229	0.043597	3434.0	3870.0	7.1693	0.034612	3422.0	3854.6	7.0540
800	0.054132	3632.0	4119.2	7.4606	0.048629	3628.2	4114.5	7.4085	0.038724	3618.8	4102.8	7.2967
900	0.059562	3829.6	4365.7	7.6802	0.053547	3826.5	4362.0	7.6290	0.042720	3818.9	4352.9	7.5195
1000	0.064919	4032.4	4616.7	7.8855	0.058391	4029.9	4613.8	7.8349	0.046641	4023.5	4606.5	7.7269
1100	0.070224	4240.7	4872.7	8.0791	0.063183	4238.5	4870.3	8.0289	0.050510	4233.1	4864.5	7.9220
1200	0.075492	4454.2	5133.6	8.2625	0.067938	4452.4	5131.7	8.2126	0.054342	4447.7	5127.0	8.1065
1300	0.080733	4672.9	5399.5	8.4371	0.072667	4671.3	5398.0	8.3874	0.058147	4667.3	5394.1	8.2819

